

SPHEROMATIC H

Precision instrument for measuring radii

For the precise measurement of the radii of curves in both convex and concave spherical surfaces such as lenses, test glass pairs, mirrors etc.

Featuring

- Extended measuring range
- Higher precision
- New SPHEROWIN measurement software
 - User friendly Windows®
 - No knowledge of computers necessary
 - Clarity in file management
 - A Statistical file which gives both quality control and production control with PC
- Allows use of all previous spherometer rings (ASKANIA/ MÖLLER)
- Digital measurement procedure



Principle of Operation

Determining the radius length is based on the calculation of the known value r (the Spherometer ring radius), the length of the rise h and in the case of the spherometer ball rings, the radius of the contact ball k .

$$R = \frac{r^2}{2 \cdot h} + \frac{h}{2} \pm k$$

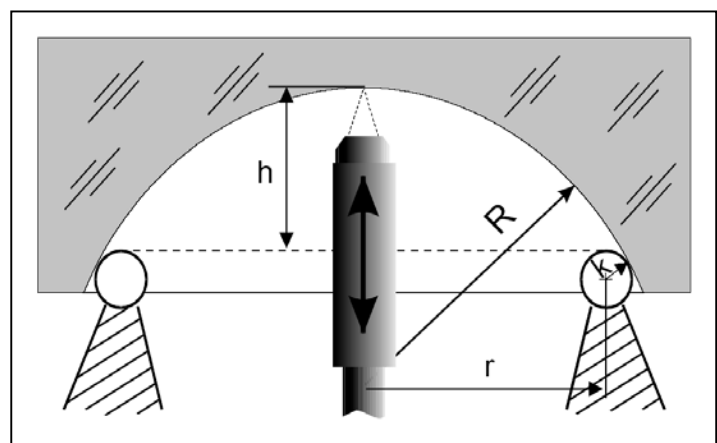

Measurement of the rise h is done by means of mechanical touching of the measurement and reference area with the aid of an incremental high-precision linear measuring system.

The rise is determined by means of establishing the difference between a reference value (as a rule a plane surface plate) and the lens to be tested. The direct measurement of test glass pairs (convex to concave) affords an additional increase in accuracy.

Extended Measurement Range with a Higher Degree of Accuracy

By using a high precision incremental linear measuring system (60mm Measuring range) powered by an electric motor we can achieve a higher degree of accuracy and reproducibility, a greater measurement range of the radius with a simplified measurement procedure in comparison to earlier spherometers.

Software Options

Main Menu

After the program is run a menu appears on the screen in which all the settings can be inputted for the measuring procedure. Previously stored basic settings for particular required measurements can be retrieved at your convenience from the File directory (e.g. according to drawing no., order no., or commission no.). On the right hand side of the menu window one finds the most important settings and options as „radio buttons“. This allows a quick overview and facilitates any desired change of the settings and options selected. The option „Prevent Option“ prevents any unauthorised modification of the measurement settings by an inexperienced user.

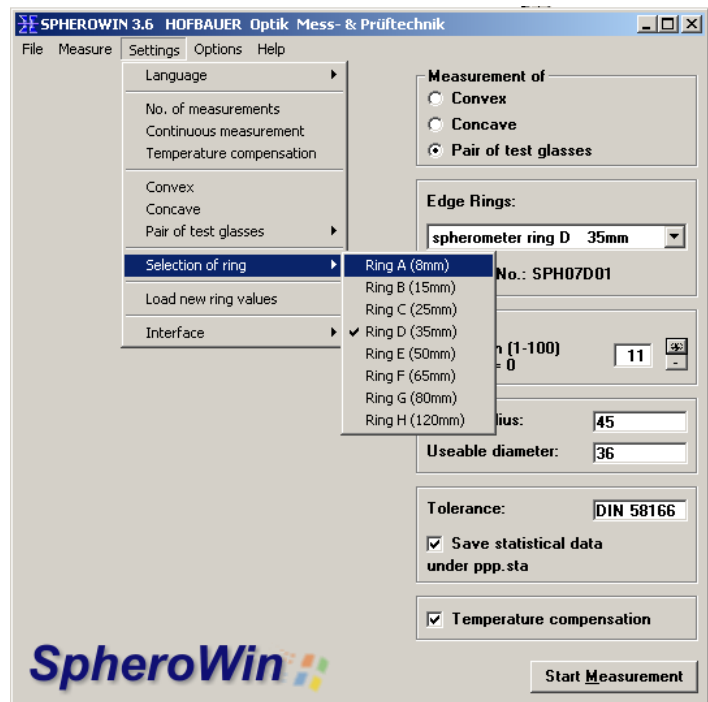

The user has the possibility of entering a desired number of repeated measurements and of tailoring the program settings to suit the measuring procedure: According to the choice of spherometer ring, ring type (ball ring, sharp edge ring), and according to the type of surface to be examined (convex / concave, pair of test glasses).

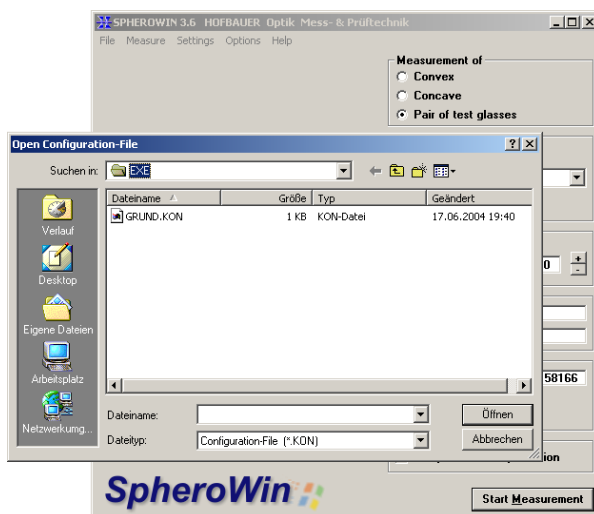

Storing of Statistical Data

An additional software accessory also available enables the continuous checking of the status or of the statistical process-control in the production or receiving of goods. For this purpose a statistical file can be created or opened in which all the important data for the statistical evaluation of relevant data (Basic setting, individual measurement readings, results, uncertainty of measurement) can be stored. This file can be converted to a spreadsheet program so as to enable further work with the data.

- The option „Store the statistics file“ enables the automatic storing of the statistical data.
- A file manager enables a simple search for the stored statistical data.

Messprotokoll

Ringtyp: Sphärometerring G 80mm
 Prüfobjekt: konvexer Prüfling
 Nennradius: 65
 Nutzdurchmes.: 89

abgelesene Werte :

	plan	konvex	plan	konvex
1	00,0000	13,0000		

Gemittelte Messwerte aus 1 Messungen

plan = 0,0000
 konvex = 13,0000
 Pfeilhöhe = 13,0000

Ermittelter Radienwert: Konkextradius = 65,0348 mm

Die Meßunsicherheit (ohne Antastunsicherheit) des Radius beträgt : 0,007mm dies entspricht 0,02%

Der Radius ist nach DIN 58166 innerhalb der Toleranz. Toleranz = 0,06%
 Die Pfeilhöhendifferenz auf den Nutzdurchmesser bezogen, beträgt 0,0129mm dies entspricht 47,4 Ringe (Bezugswellenlänge = 546 nm)

Measurement Protocol

- Records all the measurement conditions
- Presents an overview of all measurement readings
- Presents the statistical values and the measurement result along with the measuring error
- Gives information on how the measurement results tally with the Tolerance according to DIN 58166
- Gives details about the measurement deviation in the interference ring according to DIN 3140.

After beginning the measurement the instructions are simple and obvious; after each set of measurements the readings are displayed. When the required number of rows of measurement have been completed the protocol will be shown and the user may store it or have it printed out. With the aid of the protocol it is possible not only to document all the measurement data and settings, it is also possible to inform the user as to whether the radius in question lies within the tolerance given.

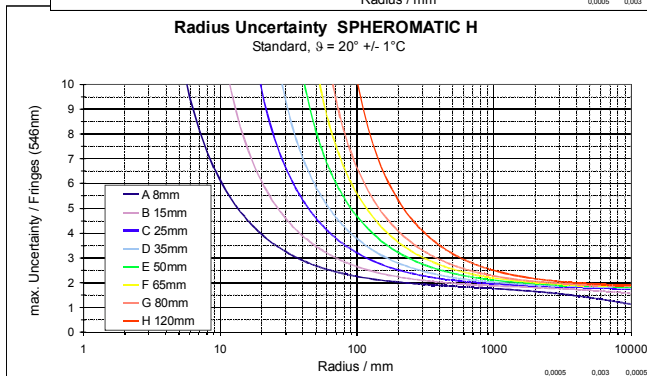
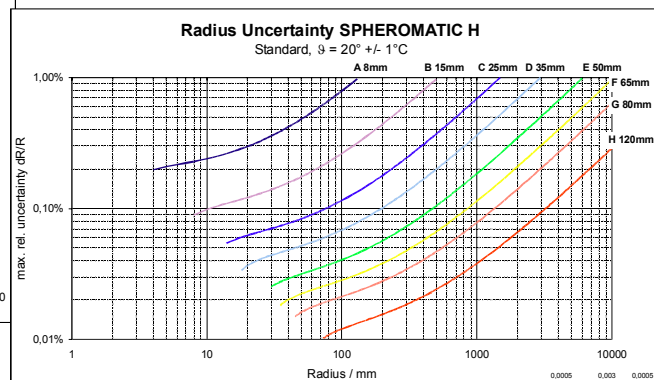
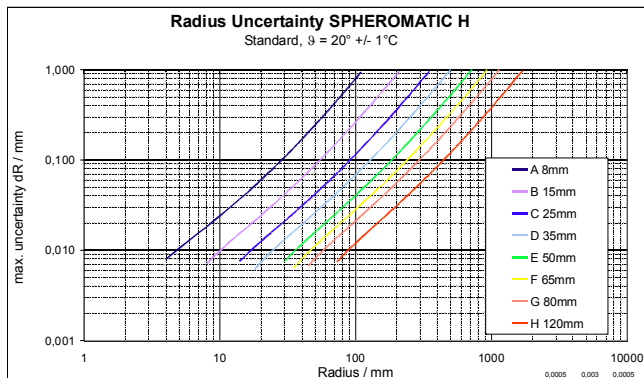

Measuring uncertainty

The measuring uncertainty depends on the relationship of the diameter to the radius of the test specimen. The diagrams show dependence on the radius with different spherometer rings. The test specimen diameter corresponds to the spherometer rings diameter of 8, 15, 25, 35, 50, 65, 80 and 120 mm in the diagram.

Tolerance Details

A window is available that permits various possibilities of tolerance. For example, in the measurement of spherical test glasses, the program contains a file with tolerances according to DIN 58166 which may be accessed. Also you may define and input your own relative or absolute tolerances.

Tolerance

No tolerance

According to DIN 58166

User defined

Technical Data

Range of Measurement:

- Range of linear measurement: ± 60 mm
- Radius R = +3.2 mm to infinity,
Radius R = - 6 mm to infinity *
- Diameter of the object 6 mm to 500 mm*

Measurement uncertainty:

Incremental linear measuring system:

- Resolution 0,1 μ m
- Accuracy with compensation $\pm 0,3$ μ m
without compensation $\pm 0,5$ μ m
- Repeatability accuracy of radius
Measurement to 0,001%
- Absolute radius measuring uncertainty
with our ball ring component to 0,01%
dependant on the ratio of diameter of the lens to its radius

Dimensions:

LxBxH: 140x140x280 mm³

Weight: 3,3 kg

System requirements:

IBM-compatible PC with 80386 processor or higher, WINDOWS 3.1x/95/98/2000/XP

Delivery includes:

Basic apparatus, Steering device, digital Counter with RS232-Interface (7 -segment LED's, 9 counting decades and sign), Basic Software Module, Lens holding device (Counter balance)

Areas of application:

- Measurement of original test glasses
- Measurement and examination of work test glasses
- Large-scale examination of lense-radii
- Radius measurement of precision spheres

For ultra high-precision measurements ask for SPHEROMATIC CERTO with precision-rubin-ball rings.

Software:

- Simple and user friendly
- Single and series measurement possible
Determination of the radius with details of the measurement uncertainty
- Noting of chance deviations in measurement
- Automatic recognition of convex and concave radii
- Tolerance can be inputted according to DIN 58166 (in rings) or absolute in mm
- Clear overview of the file management
- Output protocol can be sent to a printer or stored in memory
- Measurement mode: Individual glass and test glass pair measurement
- Increased accuracy

Accessories:

- Software extension: Storing the measured readings of systematic measurements in a statistical file e.g. in the case of large scale production
- Software extension: Increase in accuracy with test glass pair measurements ca. 25%
- Spherometerrings diameter ranges from 8 to 120 mm **
- PC laptop / printer
- Test-glass set consisting of 3 plane glasses
- Test-glass set consisting of 8 spherical test glass pairs

-
- Please send us price and delivery details about the Spheromatic H
 - Please call us for a demonstration in our premises
 - Please send us a brochure of your products and services

Name _____

Company _____

Department _____

Postal Code, Address _____

Telephone _____

Fax _____

Business Sector _____

* dependant on the spherometer ring, other ranges on request

** further details on request